

Service Manual

Minuteman[®]
Excellence Meets Clean

All E17BD, E17TD, E20BD, E20TD, E20C, H20BD, H20TD and E26ECO Automatic Scrubbers

For:
Training
Troubleshooting
Adjustments



Revised 09-11-2012

Contents

1	Safety	Page 4
2	Technical Specifications	Page 5
	2.1 Dimensions E17BD & E20BD	Page 6
	2.2 Dimensions E17TD & E20TD	Page 7
3	Maintenance Intervals	Page 8
	3.1 Customer Maintenance	Page 9
	3.2 Maintenance I after every 125 hours of operation	Page 10
	3.3 Maintenance II after every 250 hours of operation	Page 11
	3.4 Maintenance S after every 500 hours of operation	Page 12
4	Batteries and Wiring	Page 13
5	Recovery Float and Gasket	Page 14
6	Lubrication	Page 15
7	Charge Indicator	Page 16
8	On Board Chargers	Page 17
	8.1 Programming the 957745 Charger	Page 18
	8.2 Charger Settings (957745)	Page 19
	8.3 Battery Charger Trouble Shooting	Page 20
	8.4 Battery Charger Display Codes	Page 24

Contents

9	Battery and Error Code Indicator	Page 27
	9.1 E17TD and E20TD Error Codes	Page 28
10	Squeegee Adjustment (Curved)	Page 33
	10.1 Squeegee Adjustment	Page 34
	10.2 Squeegee Caster Adjustment	Page 35
	10.3 Squeegee Caster Adjustment	Page 36
	10.4 Squeegee Caster Adjustment	Page 37
11	Maintaining Deep Cycle Batteries	Page 38
12	Load Testing The Batteries	Page 40
13	Hydrometer Testing	Page 41
14	Transporting the Machine	Page 44
15	Key Switch	Page 45
16	Solution Filter	Page 46
17	Notes	Page 47
18	Service Bulletins and Additional Information	Page 48

1. Safety

1. **Stop the machine only on level surfaces.**
2. **Avoid moving parts. Do not wear loose jackets, shirts, or sleeves when working on machine.**
3. **Avoid contact with battery acid. Battery acid can cause burns. When working on or around batteries, wear protective clothing and safety glasses. Remove metal jewelry. Do not lay tools or metal objects on top of the batteries.**
4. **Do not clean machine with a pressure washer.**
5. **Only authorized personnel should perform repairs and maintenance.**
6. **Use only Minuteman genuine replacement parts.**
8. **Do not use machine around flammable substances.**
9. **The batteries should be charged only in well ventilated areas.**
10. **Always disconnect the battery pack from the machine and the A.C cord the from outlet, when servicing the machine.**

2. Technical Specifications



E17BD, E20

Specifications

	E17	E20
Cleaning path width	17 in (43 cm)	20 in (51 cm)
Squeegee width Curved	30 in (76 cm)	34 in (86 cm)
Squeegee width Straight	33 in (83.82cm)	33 in (83.82cm)
Theoretical productivity (Brush Drive)	12,750 ft ² /hr (1,185 m ²)	15,000 ft ² /hr (1,394 m ²)
Theoretical productivity (Traction Drive)	23,120 ft ² / hr (2,147 m ²)	27,200 ft ² /hr (2,527 m ²)
Working speed (Brush Drive)	1.7 mph (2.7 km per hr)	1.7 mph (2.7 km per hr)
Working speed (Traction Drive)	3.1 mph (5 km per hr)	3.1 mph (5 km per hr)
Rated voltage	24 volts	24 volts
Vacuum flow	65 cfm (110 m ³ /hr)	65 cfm (110 m3/hr)
Vacuum waterlift	45 inches (112mbar)	45 inches (112mbar)
Vacuum power	.60 hp (450 W)	.60 hp (450 W)
Drive motor power (TD only)	1/5 HP (150 W)	1/5 HP (150 W)
Brush type	Disc	Disc
Brush motor(s) power	3/4 HP	3/4 HP
Number of brushes	1	1
Brush RPM	180 RPM	180 RPM
Aqua-Stop equipped	Coming Soon	Coming Soon
Solution capacity	12Gal (45 liters)	12 Gal (45 liters)
Recovery capacity	13 Gal (49 liters)	13 Gal (49 liters)
Weight with batteries (BD only)	306 lbs (139 kg)	313 lbs (142 kg)
Weight without batteries (BD only)	196 lbs (89 kg)	203lbs (92 kg)
Weight with batteries (TD only)	365 lbs (166 kg)	372 lbs (169 kg)
Weight without batteries (TD only)	231 lbs (105 kg)	238 lbs (108 kg)
Dimensions (LxWxH)	44.4 x 18.8 x 42.3 (112.8 x 47.8 x 107.4 cm)	47.4 x 21.3 x 42.3 (120.4 x 54.1 107.4 cm)

2.1 Dimensions E17BD & E20 BD

With a Straight Squeegee

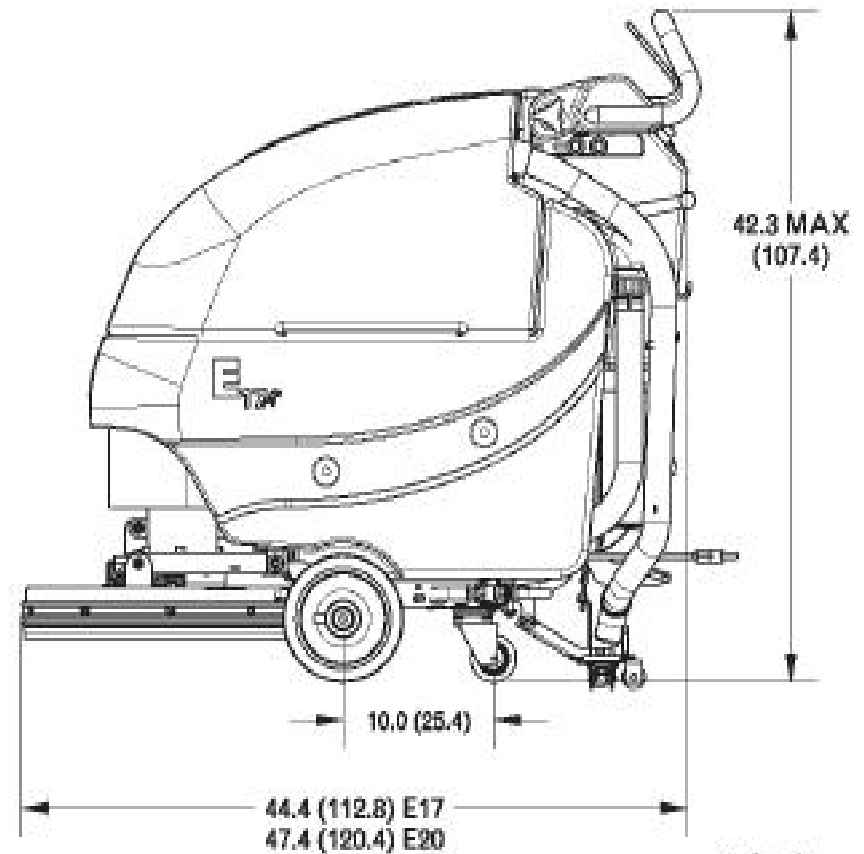
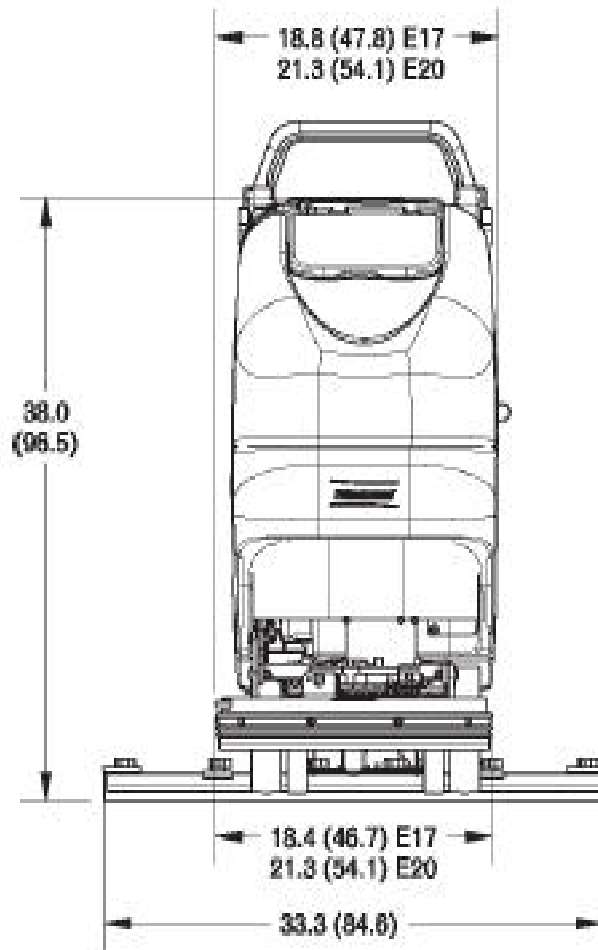

2.2 Dimensions E17TD, E20TD, E17 and E20BD

With Curved Squeegee



3. Maintenance Intervals

•**Maintenance Intervals:**

In a modular structure, the Minuteman System Maintenance determines the specific technical procedures to be performed and sets the time interval between the two maintenance cycles.

For each of the maintenance cycle, the replaceable parts are determined as well. Further details described in the specific chapters.

•**Minuteman System Maintenance K:**

To be performed by the customer (in daily or weekly intervals) according to the maintenance and care instructions as specified in the operating instructions.

The operator must be professionally instructed after delivery of the machine by selling dealer.

•**Minuteman System Maintenance I:** (after every 125 hours of operation)

To be performed an authorized Minuteman Service Center in accordance with the machine-specific system maintenance.

•**Minuteman System Maintenance II:** (after every 250 hours of operation)

To be performed an authorized Minuteman Service Center in accordance with the machine-specific system maintenance.

•**Minuteman System Maintenance S:** (after every 500 hours of operation, safety check) To be performed by an authorized Minuteman Service Center in accordance with the machine-specific system maintenance.

3.1 Minuteman System Maintenance K



To Be Performed By Customer	Interval	
	Daily	Weekly
Perform the Minuteman System Maintenance K	o	
Fill the clean water tank and mix the proper amount and type of cleaning solution.	o	
Charge the batteries.	o	
Check the brush head. Clean, if needed with a damp cloth. Do not get water inside of the motors.	o	
Check the squeegee, clean if needed.	o	
Check the lid gasket on the recovery tank	o	
Empty and flush the recovery tank with clean water.	o	
Clean the filter inside of the recovery tank. If missing replace.	o	
Check the water levels all the batteries. Add distilled water, if needed. Do not over fill.	o	
Check the brushes and pads for wear. Replace if needed.		o
Check the squeegee hose for clogs, damage and wear. Replace if needed.		o
Check the squeegee rubbers for wear and cuts. Flip the rubber blades over or replace.		o
Check the solution filter. Clean if needed.		o
Flush the clean water tank and system with warm water.		o
Test all the functions of the machine.		o

3.2 Minuteman System Maintenance I



To Be Performed By An Authorized Service Center	Interval
	Every 125 hours of operation
Perform the Minuteman System Maintenance I	0
Check the battery charger. Make sure it is functioning correctly.	0
Check the recovery lid gasket. Replace if needed.	0
Lubricate the brush lift linkages with grease. Use a small brush.	0
Check for loose hardware, tighten if needed.	0
Check the tire pressure on pneumatic wheels at 65 psi, if equipped.	0
Lubricate the squeegee linkages with grease. Use a small brush.	0
Inspect the entire machine for damage, wear and proper operation.	0

3.3 Minuteman System Maintenance II



To Be Performed By An Authorized Service Center	Interval
	Every 250 hours of operation
Perform the Minuteman System Maintenance II	0
Inspect the caster wheels for wear and damage. Repair, if needed.	0
Inspect the carbon brushes for wear in the transaxle. Replace, if needed.	0
Inspect the recovery drain hose for wear or damage. Replace, if needed.	0
Inspect the brush bumper rollers for wear or damage. Replace, if needed.	0
Inspect the carbon brushes in the brush motors for wear. Blow out with compressed air.	0
Inspect the recovery hose for damage or wear. Replace, if needed.	0
Inspect the squeegee assembly for proper adjustment. Repair, if needed.	0
Test the machine for proper operation.	0

3.4 Minuteman System Maintenance S



To Be Performed By An Authorized Service Center	Interval
	Every 500 hours of operation
Perform the Minuteman System Maintenance check	0
Replace the carbon brushes in the transaxle.	0
Replace the carbon brushes in the brush motors.	0
Test the machine for proper operation.	0

4. Batteries & Wiring

•Battery Compartment

- The battery compartment is located under the recovery tank. The battery compartment can be accessed for servicing and maintenance by tilting the recovery tank. Make sure the recovery tank is has been drained before tilting.
- The battery compartment contains two 12 volt batteries connected in series.
- Connect the batteries according the battery wiring diagram to the right.
- The recommended batteries are two 12 volt, 105 Ah deep cycle battery part number 956712 for the Wet Lead Acid type or 12 volt 100Ah Gel Maintenance Free is part number 956100. Do not use Automotive or Marine type batteries.
- When changing the type of battery (going to Gel from Wet Lead Acid or visa versa) the battery charger will need to be programmed accordingly. See Section 8.1 on Programming the Charger.

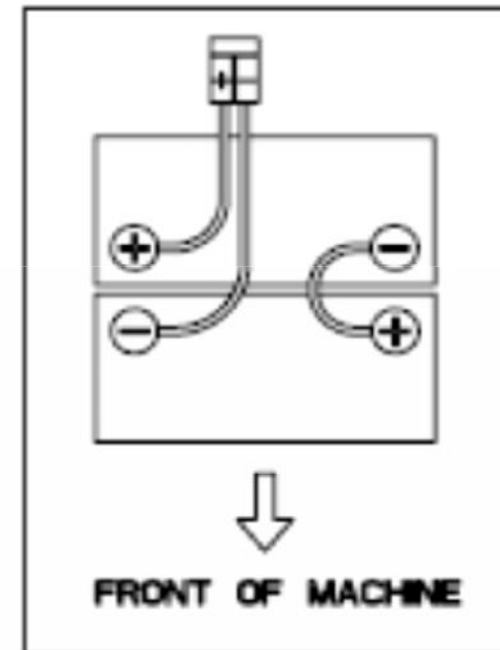

5. Recovery Float

- **The Recovery Float and Filter** is located inside of the tank,
- The filter should be checked after each use and cleaned if needed.
- Remove the three screws and the cover, to access screen float for more extensive cleaning.
- Failure to do so will reduce the vacuum performance of the machine.
- Using the machine without it in place or picking up dry material will damage the vacuum motor.

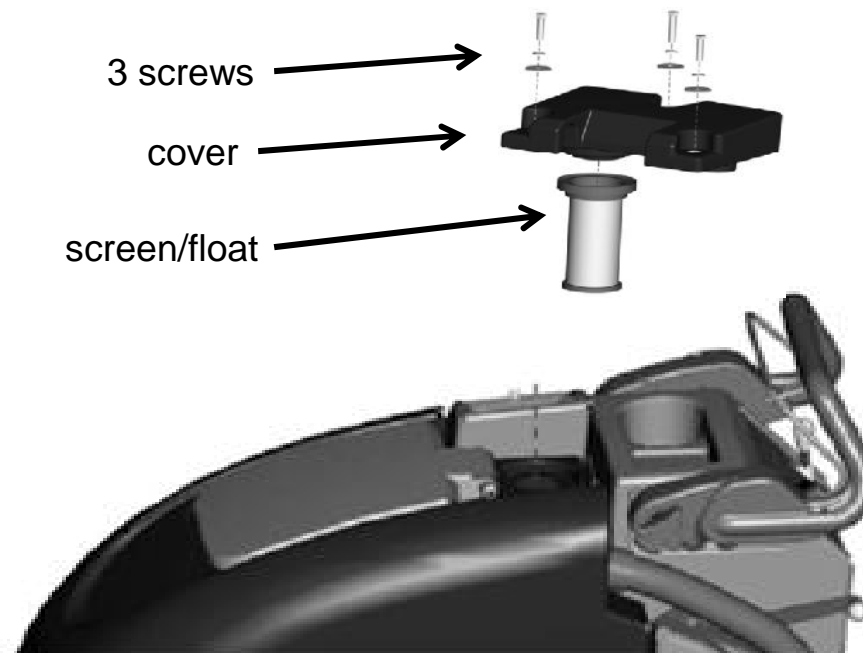

6. Lubrication

Regularly scheduled lubrication of certain machine parts should be performed to insure trouble-free operation of the machine. *Apply a generous amount of grease into the fittings on the machine until grease seeps out around the bearings. Wipe excessive grease off with a towel.*

The grease points are listed below:

- 1. Rear squeegee caster wheel axle (2)***
- 2. Rear squeegee caster swivel (2)***

Apply lubricant to:

- 1. The rear squeegee pivot points***
- 2. The scrub deck linkages.***

7. Charging Indicator

- The indicator will light during the charging process.
- The red light indicates, the batteries need a full charge.
- The yellow light indicates, the batteries have received 80% of their charge.
- The green light indicates, the batteries are fully charged.
- The red light is flashing, indicates the charger has detected a fault in the batteries. (See Section 8.6) Applies to the 957745 chargers.



8. On Board Chargers

- The Minuteman on board chargers are capable of being programmed to charge lead acid wet or gel type maintenance free batteries.
- The on board charger does has a variety of other programming settings.
- Use caution when making changes. Incorrect settings may cause the charger to malfunction and or damage the batteries.
- The 957745 charger (on left) has a series of dip switches located under the front decal that can be used to change the settings.
- The 957761 charger (on right) has a accessible rotary switch at the bottom of the charger.



957745 Charger



957761 Charger

8.1 Programming the 957745 Charger



1. Remove the large rear metal cover on rear the machine.
2. Locate the battery charger.
3. To access the Dip Switches, carefully peel the decal back on the front of the charger. Start at the bottom left side and peel up. (Removing the plastic charger cover is not necessary.) Use caution not to damage the decal.
4. There is a series of eight Dip Switches located under the decal.
5. Each switch is numbered 1 through 8.

Dip Switches 1 to 4 are for setting the type of battery.

Type of Battery	Switch 1	Switch 2	Switch 3	Switch 4
Lead Acid Wet Batteries	ON	ON	OFF	ON
AGM	ON	OFF	OFF	ON
Gel and Maintenance Free	ON	OFF	OFF	ON

8.2 Charger Settings (957745)

The dip Switches 5,6 and 7 are for selecting the amperage output of the charger. Use the 12 amp. setting only. * Note: The dip switch # 7 does not have any function at this time.

Current (Amperage Output)	Switch 5	Switch 6	Switch 7
4 AMPS	ON	ON	NA
8 AMPS	OFF	ON	NA
10 AMPS	ON	OFF	NA
—————> 12 AMPS	OFF	OFF	ON

Dip Switch 8 is to select the output voltage, either 12 or 24 volt. Use the 24 volt setting only.

Voltage Output	Switch 8
12 Volts	ON
—————> 24 Volts	OFF

8.3 Battery Charger Trouble Shooting **Minuteman**[®]

Excellence Meets Clean

(957745 Charger Only)

Trouble Shooting

1. Does the battery charger turn on when plugged into the A.C. outlet?
2. Can you hear the cooling fan turn on? If not, check the A.C. outlet for power.
3. Try a different outlet, if needed.
4. If it still doesn't turn on, inspect the A.C. cord. Repair if needed.
5. If the A.C. cord is Ok, check to see if the battery connector has been plugged in to the machine's connector.
6. Inspect the battery cables. Make sure they are clean and tight.
7. Test the voltage of the batteries; it must be above two volts minimum, before the charger will turn on.
8. If everything above checks OK, and the charger still doesn't turn on or doesn't have any output, replace the battery charger.

8.3 Battery Charger Trouble Shooting

(957745 Charger Only)

The Charger Turns On

1. If the charger appears to turn on, remove the rear metal cover on the rear of the machine.
2. The charger's display should be lighted, when plugged in the A.C. outlet. If not, replace the charger.
3. Check for errors on the chargers display.
4. Press the number 5 on the charger decal.
5. This will display different pieces of information about the charging process such as errors
6. (see error list), battery voltage, output amperage, hours of charging and estimated amp hour of battery and wattage.
7. The voltage and amperage output should start to climb after a few minutes of starting the charger, unless batteries are still hot from charging. If not, replace the charger.

8.3 Battery Charger Trouble Shooting

Excessive Gassing or Water Consumption in Batteries

1. If the charger appears to be charging and excessive gassing or water consumption had been or is occurring in the batteries.
2. Check the following:
 - A.** Have the batteries been maintained on a consistent basis? Failure to maintain batteries will shorten their life and reduce their performance.
 - B.** Test the batteries with a hydrometer. The batteries should be fully charged and cooled for 2 hours after charging, before testing. top the batteries off with distilled water prior to charging, if needed. Do not over fill.
 - C.** Compare the cell readings of all the cells in each battery

8.3 Charger Trouble Shooting

Excessive Gassing or Water Consumption in Batteries Continued

- The greater the variation between cells in any one battery, the greater loss of running time.
- A battery with variations of .040 or greater should be replaced.
- The variation of .020 is considered normal.
- Specific Gravity Readings are as follows:
 - 1.280 and above = 100% charged cell
 - 1.235 to 1.240 = 75% charged cell
 - 1.190 to 1.195 = 50% charged cell
 - 1.150 to 1.175 = 25% charged cell
 - 1.250 and less = 0% charged cell
- Load test the batteries with a battery load tester.
- The voltage difference should be less than 1 volt, when testing under load.
- Any battery that has 1 or more volt(s) less than the other should be replaced.

8.4 Battery Charger Display Codes

957745 Chargers



Codes that could be displayed on the charger are as follows:

“Bat” = The batteries are not detected. Voltage is below 2 volts,
The polarity could be reversed or batteries disconnected.

“Acd” = the charger programming set for wet lead acid batteries. (not an error)

“Gel” = charger programming set for gel batteries (not an error)

“E01” = maximum battery voltage has been reached.

“E02” = charger is overheating, faulty cooling fan or the cooling air to charger is obstructed.

“E03” = the batteries have exceeded the normal charge time. Possible battery sulfation has occurred. Cycle the batteries several times (charge and discharge).

“Sct” = safety timer operation. This normally occurs after any allotted phase time period has expired.

“Srt” = internal short circuit in charger. Replace the charger.

8.5 Programming the 957761 Battery Charger

Instructions

1. Remove the rear metal panel on the machine.
2. Remove the 957761 charger completely from the machine.
3. Locate the rubber plug on the bottom right side of the charger.
4. Remove the rubber plug.
5. Locate the selector switch.
6. Use a small flat tip screw driver to turn the red indicator to the desired setting. See the chart below.
7. Replace the rubber plug and install charger into the machine.

Switch Position	Battery Type
1	Flooded Lead Acid Part # 956712 (115 AH)
1	Minuteman AGM (95AH) Part # 956100 (Note: Replaces the gel battery) Used after 5/11/2011
2	Flooded Lead Acid Part # 956140 (140 AH)
3	Gel Maintenance Free Part # 956135 (135AH)
4	Gel Maintenance Free Part #956100 (95 AH) Used before 5/11/2011

Note: These are the only settings available. For non OEM batteries, select from the list above. The remaining settings do not have any additional functions.



Bottom view with plug



Bottom with plug removed

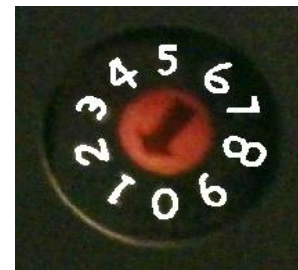

Selector Switch close up

8.6 Battery Charger Fault Codes

957761 Charger Only

Faults are displayed red LED on the battery charge indicator.

RED LED BLINKS ONCE AND REPEATS: OUTPUT CONNECTION ERROR.

1. Check for loose or corroded connections between the charger and the batteries.
2. The output may be shorted due to improper connection to the batteries or pinched wires.
3. The output may be connected in reverse polarity to the batteries.
4. The battery voltage may be too high (higher than a 24V battery pack).

This condition can also occur, if the charger is restarted immediately after charging.

Allow batteries to cool down before restarting the charger.

Note: The charger is not damaged by any of these problems except when connected to Batteries totaling 48 volts or more.

RED LED BLINKS TWICE: CHARGER HAS TIMED-OUT

The charging progress timer has elapsed before charging was complete and charger has stopped charging. Possible causes:

1. The batteries are extremely discharged – Unplug the AC cord connection for 30 seconds minimum. Let batteries cool down if hot. Reconnect the AC cord to start a new charge cycle.
2. The electrolyte is low in one or more cells – Correct by adding distilled water.
3. Batteries are weak, old, or have one or more bad cells. Batteries will still charge but capacity will be reduced. Replace the batteries, if needed.
4. If batteries are new, the batteries may need to be conditioned by charging and discharging them. Some batteries may need to be cycled several times in order to condition them to their full potential.

8.6 Battery Charger Fault Codes Cont.



Faults are displayed red LED on the battery charge indicator cont.

All Three lights blink at the same time

1. Charger is restarting
2. Charger is unable to put full output to the batteries
3. Possible loose or poor connections. Check all connections.
4. Batteries may need to be conditioned by charging and discharging them.
Some batteries may need to be cycled several times in order to condition them to their full potential.

9. Battery and Error Code Indicator

Traction Drive Models only

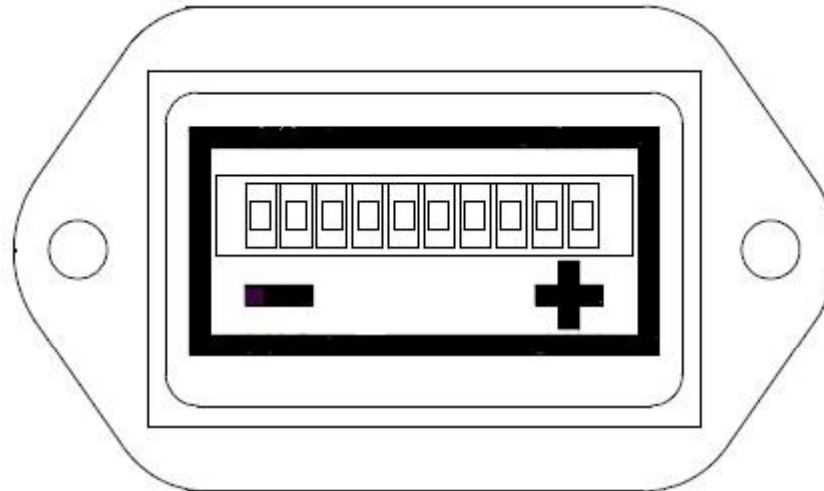

- The indicator will display the charge status during machines operation. The indicator uses ten LEDs. 1 to 10 LEDs may be illuminated at any given time. 10 being a fully charged battery pack. 1 LED would be a discharged battery pack.
- The indicator will also will display errors by rapidly flashing 1 to 10 LEDs. See the following references for the type of error that it has detected.

9.1 E17TD And E20TD Error Codes



1 Bar = Low Battery Voltage

The battery needs charging or there is a bad connection to the battery. Check the connections to the battery. If the connections are good, try charging the battery.



2 Bars = Traction Motor Disconnected

There is a bad connection to the Traction motor. Check all connections between the motor and the control system.



3 Bars = Traction Drive Motor Shorted

There is a short in the Traction Drive circuit. Possible short in the drive motor or harness.

9.1 E17TD And E20TD Error Codes



4 Bars = Battery Lockout

The traction drive controller has shut down because of low battery voltage. Charge the batteries. If problem still exists: Test batteries and check all battery connections.



5 Bars = Not Used



6 Bars = Drive Inhibit

The drive circuit is inhibited when charger is plugged into a A.C outlet. Turn the key switch off while charging.

9.1 E17TD And E20TD Error Codes



7 Bars = Throttle Trip

A throttle trip is indicated. Make sure that the throttle is in the rest or neutral position before turning on the scrubber. Test the potentiometer circuit.



8 Bars = Control System Trip

A control system trip is indicated. Make sure that all connections are secure.



9 Bars = Not Used

9.1 E17TD And E20TD Error Codes



10 Bars = High Battery Voltage

An excessive voltage has been applied to the control system. connections. This is usually caused by a poor battery connection. Check the battery connections.



No Bars = Control System in Sleep Mode

The control system has entered sleep mode. Switch the control system off and then on again.

9.1 E17TD And E20TD Error Codes



Bridge Charge Step

This is an initialization message. It should only appear if a control system is connected to a battery and turned on within 10 seconds.



Ripple = Throttle Displaced

The drive switch has been activated while turning on the machine. Place the throttle in the neutral position and turn the control system on and off again. Possibly the drive switch is stuck on.

10. Squeegee (Curved)

10.

Rear Squeegee

- A Squeegee
- B Star-shaped knob
- C Adjusting screw for angle adjustment
- D Suction hose
- E Blade fastening device
- F Washers for caster height adjustment

Cleaning the Squeegee

Check the squeegee (A) daily and clean as necessary.

1. Pull off the suction hose (D).
2. Loosen the two star-shaped knobs (B).
3. Remove the squeegee (A).

Changing the Squeegee Blades

Check the inner and outer squeegee blades on the squeegee (A) weekly for signs of wear. The squeegee blades can be reused by turning them.

1. Pull off the suction hose (D), loosen the two star-shaped knobs (B) and remove the squeegee.
2. Unlock the fastening device (E) and remove the outer squeegee blade. Turn the squeegee blade or install a new one, as necessary. Change the inner squeegee blade in the same way.

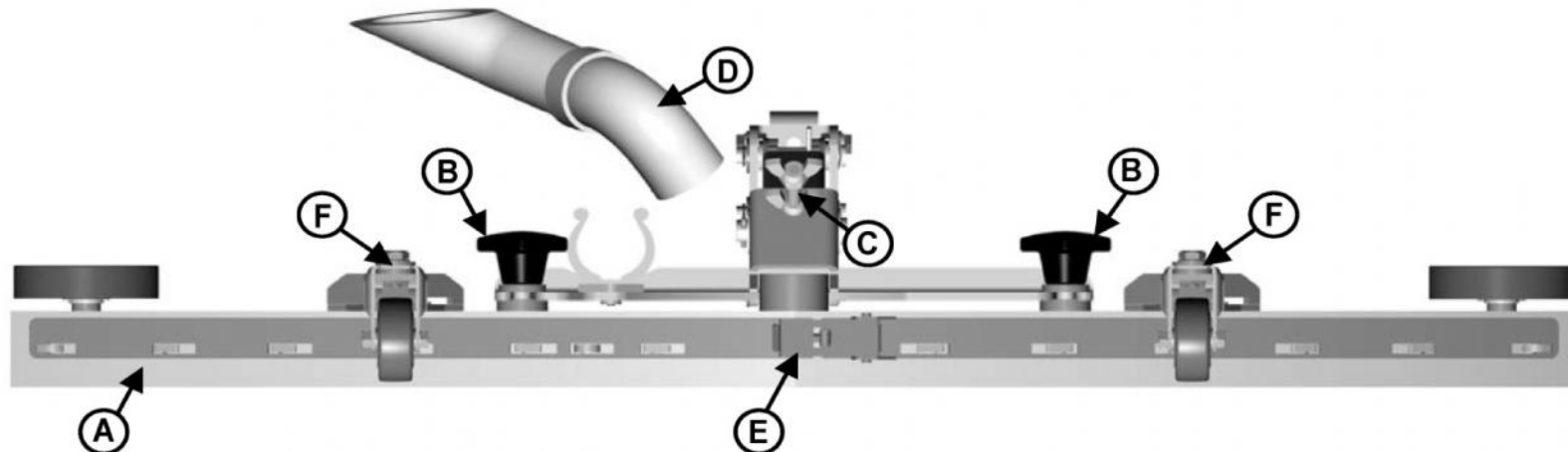

10. Squeegee (Curved)

10.1

Adjusting the Squeegee Blades Angle Adjustment

The angle adjustment is the decisive factor in ensuring that the squeegee blades on the squeegee lie evenly on the floor.

1. Park the machine on a level surface and lower the squeegee.
2. Loosen the lower wing nut (B) on the adjusting screw (C) and adjust the squeegee using the adjusting screw so that the ends of the squeegee blades still have contact with the floor. By turning the adjusting screw (C) counterclockwise, the clearance between squeegee blade and floor is **reduced** in the center (Fig. 1). When turning the adjusting screw (C) clockwise, the clearance between squeegee blade and floor is **increased** in the center (Fig. 2).
3. Switch the machine on and check the suction pattern. When the machine is in operation, the entire surface of the squeegee blades (center and outer areas) must be applied as evenly as possible.
4. Tighten the lower wing nut (B) on the adjusting screw (C) against the metal bracket to lock in the pitch setting.

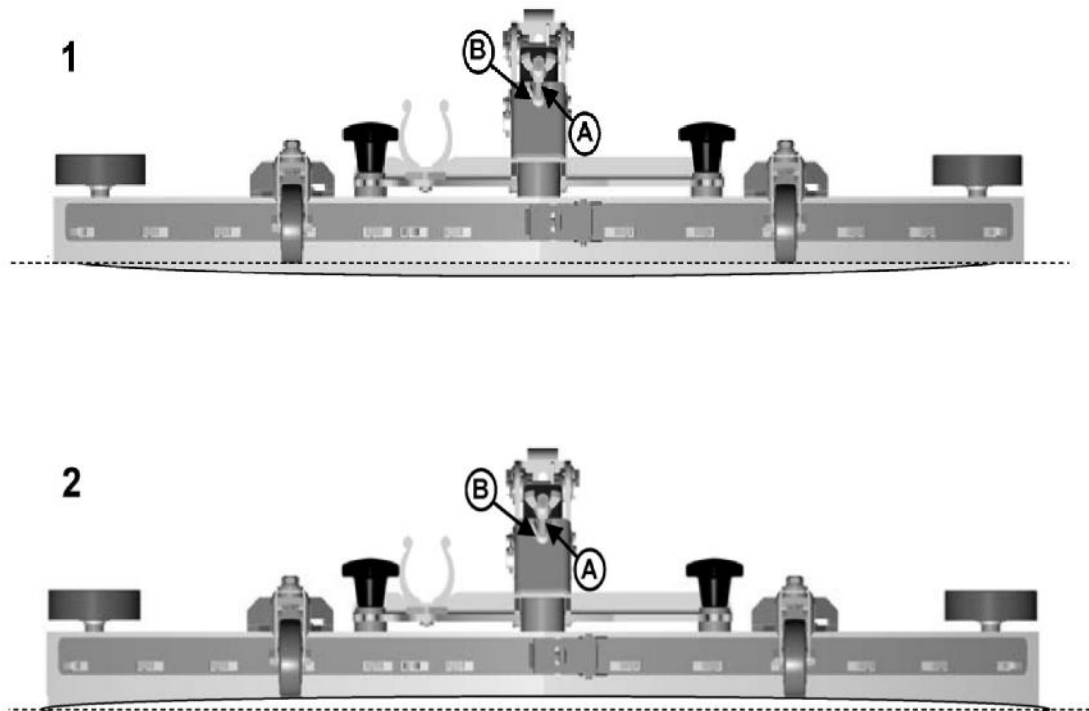

10. Squeegee (Curved)

10.2 Clearance between support roller and floor with unfolded sealing strip (Factory presetting): 3 mm \pm 0.5 (Fig. 5/2).

Place additional 1mm spacers (pos. 15, Fig. 5/3) between the angle and the fixed roller housing (pos. 7, Fig. 5/3) to increase clearance or remove existing 1mm spacer from between the angle and the fixed roller housing in order to reduce the clearance. Re-insert the spacers removed from between the angle and the fixed roller housing again above the fixed roller housing to allow complete tightening of the screws.

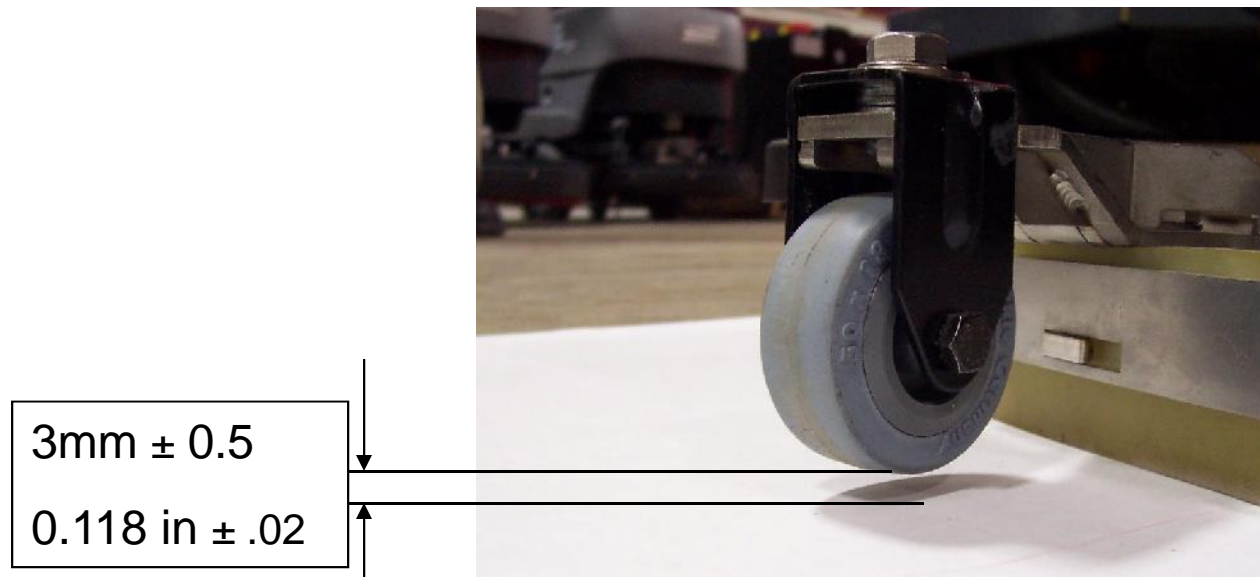

10. Squeegee (Curved)

10.3 Curved Squeegees Only

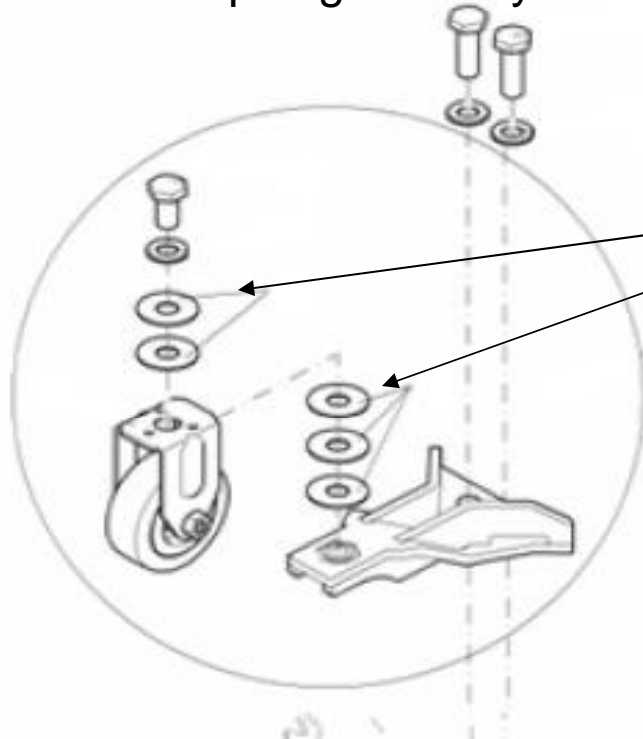

Washers may be rearranged to change the height of the squeegee caster.

Note: When adjusting the wheel height, there should always be 5 washers on each wheel assembly in order fully tighten bolts. Move washers from the top to the bottom of the bracket or visa versa when making adjustments. See following page.

10. Squeegee (Curved)

10.4 Curved Squeegees Only

- Possible squeegee caster washer combinations.

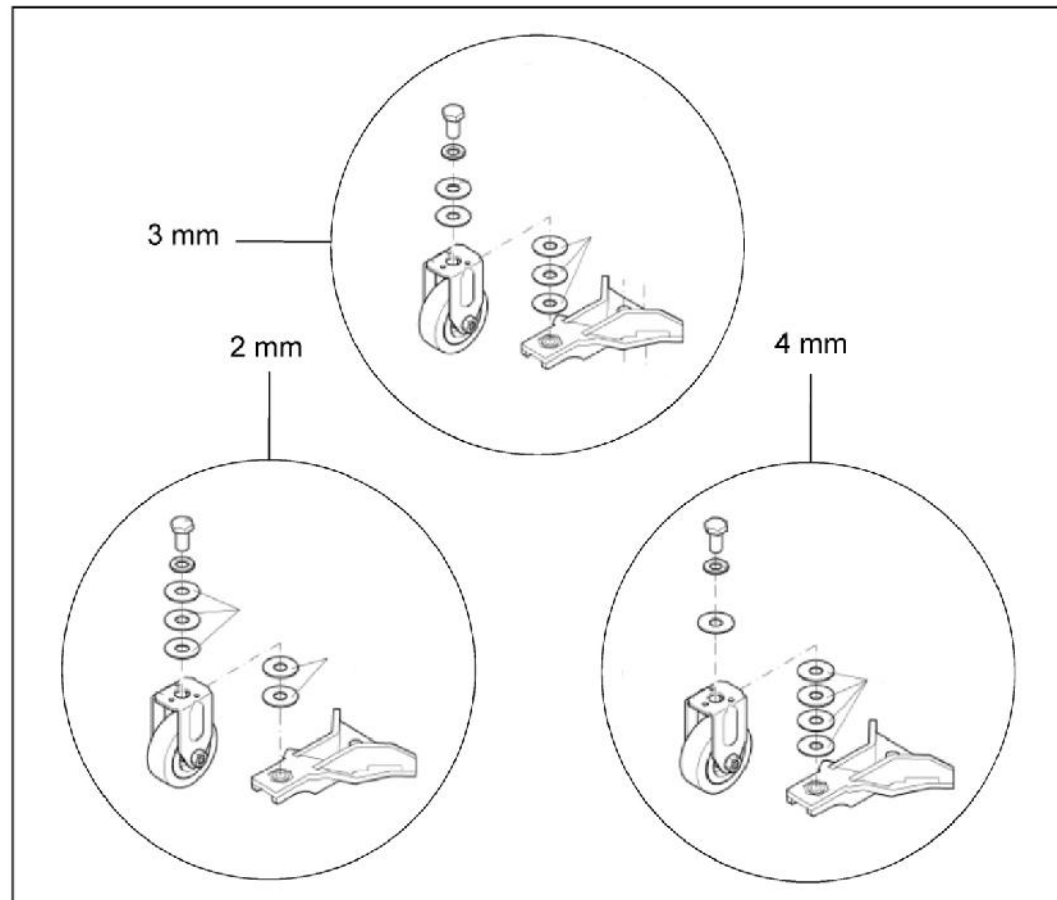

11. Maintaining Deep Cycle Batteries

1. Always keep the water levels above the plates
2. Fill the batteries with distilled water only. Tap water can cause an excessive build up of minerals and reduce the chemical reaction of the batteries. This will shortening the life and performance of the batteries.
3. Use appropriate filling devices when filling the batteries. Do not use a garden hose or metal containers. Flooding the batteries can flush the electrolyte out of the battery and shorten its life.
4. Fill cells $\frac{3}{8}$ to $\frac{1}{2}$ of an inch above the separators. Do not fill above the fill marker of the batteries. Over filling can cause the electrolyte to percolate out onto the case while charging.

11. Maintaining Deep Cycle Batteries

5. Check water level daily. Fill, if needed.
6. Keep all the battery cable connections tight.
7. Keep all the battery posts and cables clean. Clean the battery cases with a mixture of baking soda and water solution or commercial spray that neutralizes the acid. Spray the cases with a water displacement chemical or a silicone. This will help break the flow of current across the case and increases the life of the battery.

Note: The electrolyte on the surface of the case can cause:

- A. The batteries to discharge faster even while sitting and have a shorter run time.
- B. The battery charger to stay on for extended periods. Thus causing an over charge condition and shortening the life of the batteries.

12. Load Testing The Batteries

- **Load test battery with an automotive type load tester. This test puts an ampere load on the batteries and measures the voltage at the same time.**
- **If voltage drops too low on the meter, this would indicate that the batteries are weak or discharged.**
- **A fully charged good battery should test in the good or green range of the meter. Load testing can identify dead cells, broken or disconnected plates, weak cells and charge status.**
- **This is good test, however it can only detect these types of failures.**
- **Most load testers require putting a load on the batteries for 10 seconds.**
- **Load testing may not detect all short run time issues.**

13. Hydrometer Testing The Batteries

- Hydrometer testing can be used to measure the specific gravity of deep cycle batteries. This allows you to detect weak cells, which are causing loss of running time. It can only detect this type of problem. The hydrometer should have specific gravity markings such as 1.265, 1.250, 1.225, and so on.
- Hydrometers with the four balls are not accurate enough for this test and are not recommended.
- Fully charged batteries should read 1.265 and will decrease as batteries are discharged until they reach 1.120. This test should be done when batteries are charged and cooled. Allow one hour or more to cool. It can also be done after batteries are partially discharged, if they are allowed to cool. However, you will not be able to detect the full capacity of the battery.
- Note:** Maintenance Free batteries can not be tested with a hydrometer. Do not attempt to remove caps or covers. This will destroy the battery.

13. Hydrometer Testing The Batteries

•Hydrometer Testing

- To do an accurate test, the battery water level must be high enough to extract enough electrolyte to fill hydrometer so that the float floats. Water should be added prior to charging in order for let the electrolyte to mix.
- The greater the variation between cells readings, the greater the loss of run time. For example, if the readings are 1.265, 1.265 and 1.225 in one 6 volt battery. The low cell would be considered weak and greatly reduce the performance of the battery or shorter run time. This battery would have a point 40 variation. Batteries that have weakened cells in most cases it can still be used as long they continue provide adequate run time. A battery with a point 40 variation or more should be determined defective.

13. Hydrometer Testing The Batteries



- **Minuteman batteries are rated for about 500 charge cycles. The life of the battery will be greatly dependent by the maintenance they receive.**
- **Every time the batteries are charged it uses one cycle.**

- **The specific gravity will reflect the percentage of charge remaining in the battery.**
- **100% charge = 1.265 Specific Gravity**
- **75 % charge = 1.225 Specific Gravity**
- **50 % charge = 1.190 Specific Gravity**
- **25 % charge = 1.120 Specific Gravity**

- **Note : Gel maintenance free batteries can not be tested with the hydrometer. Do not attempt to open cell covers or caps. Doing so will destroy the battery.**

14. Transporting The Machine

When transporting the machines on a trailer or truck always:

- **Tie down the machine securely.**
- **Lower the brush head assembly completely to the floor.**
- **Turn the machine off.**
- **Failure to do the above may result in damage to the machine.**

15. Key Switch

- The key switch has 8 terminals. Below shows the three different switch functions. The black bars indicate the internal connection made by the switch in each position.

Switch Off

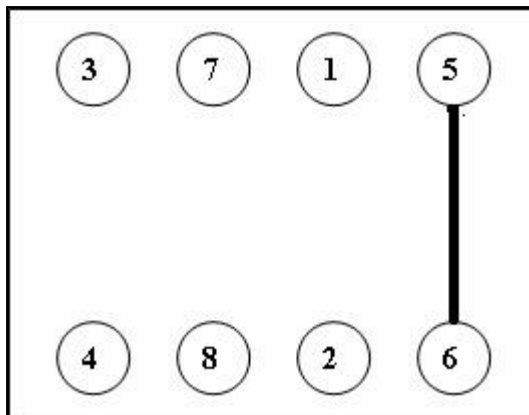

Switch On

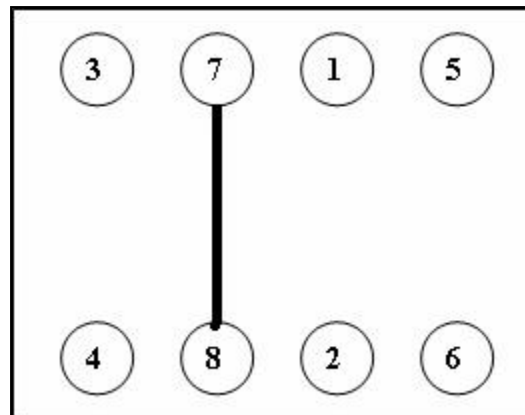

Switch Unload

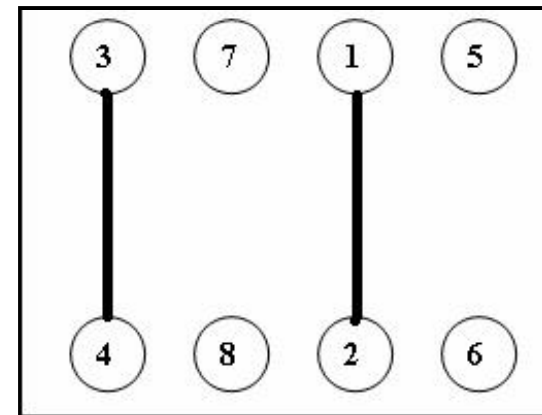

16. Solution Filter

16.

In-Line Solution Filter Assembly

The solution solenoid, which shuts off solution flow when the bail handle is released, is protected from debris by the in-line filter assembly. The filter assembly is located at the rear of the machine on the left hand side, just under the solution tank. It is important to check and clean the screened washer inside the assembly regularly to ensure proper solution flow. To open, unscrew the assembly (Note that the cone of the washer is facing out toward the rear of the machine). Remove washer and rinse, reinsert and screw assembly together, tightening by hand. **Overtightening with tools may damage the plastic threads.**

- A Fitting, MGHT
- B Screened Washer
- C Hose Barb Insert
- D Fitting, FGHT

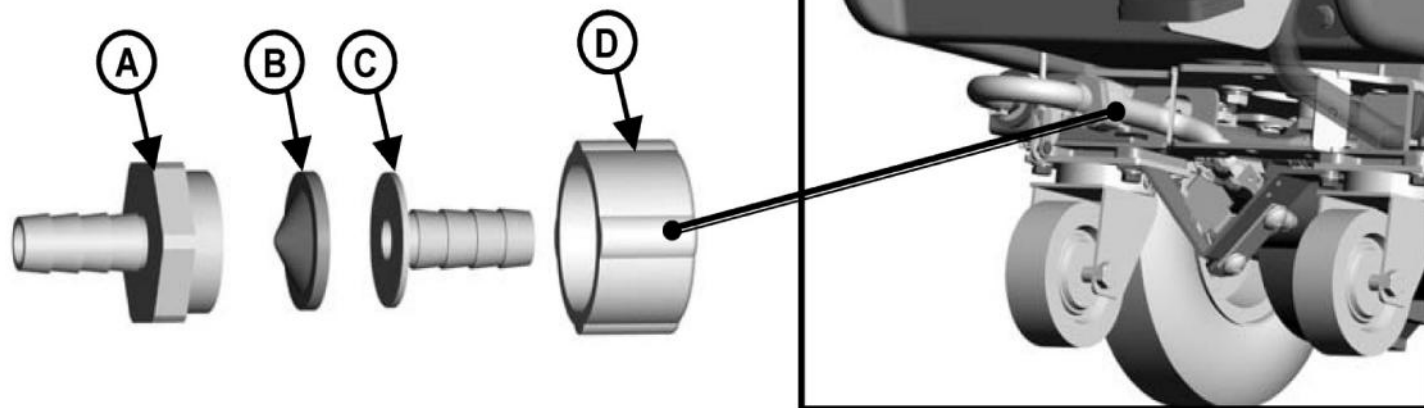

17. Notes